

# FIGHTER FK1225

**EURO 6** • 4x2 • **MANUAL** OR **ALLISON AUTO**



**GVM:**  
12,000kg



**Power / Torque:**  
184kW / 761Nm



**Wheelbase:**  
4,270mm (H) / 5,210mm (L)

- **NEW** Euro 6 drivetrain
- **NEW** Advanced safety features
- **5yr / 300,000km Warranty** (T&Cs inside)
- High-torque engine
- Low-height chassis

# SPECIFICATIONS - FIGHTER FK1225 EURO 6

## MODEL

4x2 FK1225H	6 SP.	MAN	STEEL SUSP.	FK62FHZ5RFAC(D)
4x2 FK1225L	6 SP.	MAN	STEEL SUSP.	FK62FLZ5RFAC(D)
4x2 FK1225L	5 SP.	AUTO	STEEL SUSP.	FK62FLZ5RFAD(D)
4x2 FK1225L	5 SP.	AUTO	AIR SUSP.	FK65FLZ5RFAD(D)

## WHEELBASE (mm)

4,270 (H)
5,210 (L)
5,210 (L)
5,210 (L)

## GVM (kg)

12,000
12,000
12,000
12,000

## GCM (kg)

N/A
N/A
N/A
N/A

## ENGINE

Engine Version	FUSO 6M60-CAT5 Diesel
Configuration	6 Cyl. In-line OHC, 4-Valve
Type	Variable Geometry Turbo Charged Air to Air Intercooler
Displacement	7.5 litre (7,545cc)
Power ECE Nett	177kW @ 2270rpm
Torque ECE Nett	745Nm @ 950 - 2270rpm
Power (JIS Gross)*	184kW (250ps) @ 2270rpm
Torque (JIS Gross)*	761Nm (561lb/ft) @ 950 - 2270rpm
Maximum Engine Speed (rpm)	2900
Compression Ratio	16.0:1
Cooling System/Oil Cooler	Watercooled with Electronically Controlled Viscous Fan, 23L capacity. Engine oil cooler
Air Cleaner	Paper Element Type with Restrictor Indicator. Vertical Intake Mounted on Clean Air Side (RH)
Cold Start Preheat	Standard
Emission Control	Selective Catalytic Reduction (SCR + DPF)
Emission Level	EURO 6

\*Calculated

## 6M60-CAT5

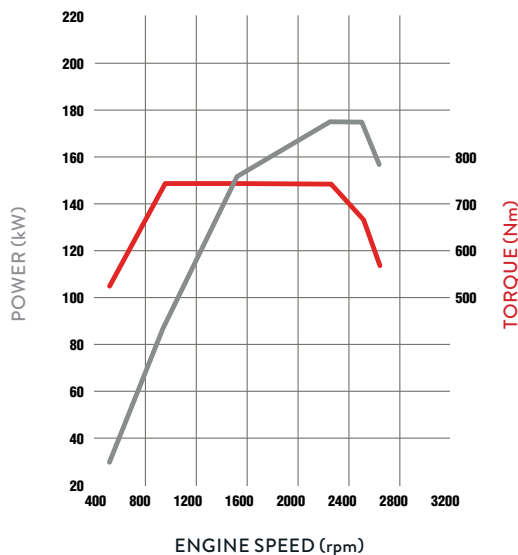

## FUEL

Injection System	DENSO Common Rail System Electronically Controlled Direct Injection
Tank Type	Rectangular Steel Tank with Locking Cap
Fuel Capacity (L)	200
AdBlue Exhaust Fluid Capacity (L)	23

## ELECTRICAL

Voltage	24V Negative Earth
Alternator Capacity	24V-80 amp
Battery Specification	Heavy Duty 2 x 12V, 100Ah/20hr

## CLUTCH (manual)

Clutch Model	FUSO C7M38
Type	Single Plate Cerametallic 380mm
Operation/Specification	Air Assisted Hydraulic

## TRANSMISSION

	Manual	Auto
Version	FUSO Manual M070S6-OD	Allison Automatic 2500 Series
Type/Speeds	6 with Air Assisted Gearshift	5 Speed with Power / Economy Mode
Features	Synchromesh 2nd-6th	Generation 5 Control Systems
Ratios	1st: 6.807 2nd: 4.172 3rd: 2.396 4th: 1.504	1st: 3.512 2nd: 1.896 3rd: 1.439 4th: 1.000 5th 0.737 Rev. 5.086
PTO Opening	LH Side	LH and RH Side
Torque Converter/ Stall Torque Ratio	N/A	TC222/1.58
Auto Transmission Fluid Cooling	N/A	Cooler mounted in front of radiator

## PROPELLER SHAFT

	Manual	Auto
Type	P10	P8
Universal Joint	Needle Roller	

## FRONT AXLE

Axle	FUSO F500T "I" Beam
Design Capacity (kg)	5,000
Max Operating Capacity (kg)	5,000

## FRONT SUSPENSION

Type	Taper Leaf Spring + Double Acting Shock Absorbers. Stabilizer Bar standard (FK62 models)
Size (mm)	1,300 x 70

## REAR AXLE

Axle	FUSO D052 Full Floating Hypoid
Design Capacity (kg)	9,500
Max Operating Capacity (kg)	9,200
Ratio	Manual 4.875:1    Auto 5.428:1

## REAR SUSPENSION

Type	Steel Suspension	Air Suspension
Details	Multi Leaf Spring + Stabiliser Bar	Trailing Arm + Air Dump Control and Double Acting Shock Absorbers & CLCS
Size Main Leaves (mm)	1,300 x 70	Air Spring (2 x 270 dia. per axle)
Size Helper Leaves (mm)	900 x 70	Chassis Level Control System, Electronic Height Control via steering wheel, 2 memory positions

## STEERING

Power Assisted	Tilt/Telescopic Adjustable Steering Wheel
----------------	---

# SPECIFICATIONS - FIGHTER FK1225 EURO 6



## BRAKES

Type	Full Air, Dual Circuit, FUSO Taper Roller, Automatic Brake Adjustment, ABS
Size Front / Rear (mm)	370 x 150
Park Brake	Rear Wheel Spring Actuated
Auxiliary	Exhaust Brake
Compressor	Water Cooled, 340cc Single Cylinder with Air Dryer

## WHEELS AND TYRES

Wheel Type	7, Steel 19.5 x 6.75" ISO 8 Stud
Tyre Size (all)	265/70R19.5
Spare Tyre Carrier	Provided

## CHASSIS

Type	Parallel Channel
Size (mm)	230 x 80 x 8.0
Width (mm)	844
Refer to guidelines on <a href="http://www.fuso.co.nz">www.fuso.co.nz</a> before mounting body/modifying chassis	

## INSTRUMENTS

Gauges	Speedo, Tacho, Air Pressure, Fuel, Ad Blue
Multi-Information Display (accessed from steering wheel buttons)	Hour Meter, Tripmeter, Outside Temp, Digital Speedo, Advanced Safety Systems control/warning, Water Temp, Fuel Consumption/Range, Cruise Control, DPF Information, Warning Lamps, Service Indicators, Oil Level, Alarm clock
Steering wheel controls	Audio /Phone/ Cruise control / Multi-Information Display menu, Air suspension height, Idling speed adjustment

## STANDARD FEATURES

Driving	Electric Windows, Keyless Central Locking, Fluorescent Cabin Lamp, Interior Reading Lamps, Engine Idle Speed Control
Storage	Centre Storage Console, Rear Bunk Storage Pocket, Dash Storage Tray 2 DIN Glove Compartment, 1 Single & 1 Double DIN Slot for Accessories, Overhead Storage Pocket with Lid, RH Door Storage Pocket, Cup Holders (4)
Cab Cooling/Heating	Air Conditioner / Heater / Demister
Accessory Power	24V Accessory Power Outlet

## CAB FEATURES

Type	All Steel Forward Control, Manual Tilt 44 deg.
Mounting	Hydroelastic Susp. 4 Point
Colour	Natural White (W31)
Interior	Fully Trimmed + Heavy Duty Vinyl on floor
Door	90 degree Opening Angle
Seat (driver)	ISRI Air Susp. + Auto Levelling, Height, Tilt, Lumbar, Bolster + Dampening Adjust, Integral Headrest, Fabric Trim
Seats (passenger)	Centre: Low Back with Fabric Trim and Forward Folding Far Passenger: Fixed Base with Reclining Seat Back, Integral Headrest and Fabric Trim
Seating Capacity	3
Cab: External	Roof Mounting Points (max. static load 50kg), Front End-Outline Marker Lamps

## SAFETY FEATURES

### ACTIVE SAFETY FEATURES

Electronic Stability Control	Yes	<b>NEW</b>
Active Emergency Braking System	Yes	<b>NEW</b>
Lane Departure Warning System	Yes	<b>NEW</b>
Active Attention Assist	Yes	<b>NEW</b>
Active Side Guard Assist	Yes	<b>NEW</b>

### CAB

Structure	Reinforced, Side Door Intrusion Beams, Transom Window and Rear Quarter Glass, Front Underrun Protector Beam	<b>NEW</b>
Airbags	Driver Air Bag and Seat Belt Pre-tensioner	
Seatbelts	2 ELR Lap Sash, 1 Lap in centre seat	
Steering Wheel	Energy Absorbing, Tilt / Telescopic Adjustable	
Headlamp Auto Sensing	Halogen 2 x 70W / 75W	<b>NEW</b>
Day Time Running Lights	Yes	<b>NEW</b>
Fog Lamps	Yes	<b>NEW</b>
Rearview Mirrors	Remote Control / Heated with separate convex Spotter (Both Sides)	
Wipers	Auto Sensing	<b>NEW</b>
Keyless Central Locking + Immobiliser	Yes	<b>NEW</b>
6.2" Touchscreen Media Unit	AM/FM/DAB + USB + AUX, Apple Carplay / Android Auto, Wi-Fi enabled, Bluetooth, 32GB storage, HD Infrared Reverse Camera	
Connectivity	FMS CANBus Connector, ASAM Sensor Actuator Module	<b>NEW</b>

### CHASSIS

Speed Limiter (100km/hr factory Set)	Yes (adjustable by FUSO dealer)	
Cruise Control	Yes	
Exhaust Brake	Yes	
Anti-Lock Brakes (ABS)	Yes	
Hill Start System	Yes (not available on auto model)	
Traction Control (ASR)	Yes	
Reverse Warning Buzzer	Yes	

## OPTIONS

Additional Cameras for Media Unit (up to 4), Truck Specific GPS Navigation, Reverse Sensors, Tyre Pressure Monitoring System (up to 36 tyres)

## SERVICE INTERVALS

20,000km or 12 month full service intervals, depending on application/use.

## WARRANTY

**5 years / 300,000km cover**  
Simply have your vehicle serviced at an authorised FUSO Service Centre, at the recommended servicing intervals, and you are covered by an additional 2 year / 150,000km FUSO warranty on top of the first 3 years / 150,000km. That's a total of 5 years / 300,000km cover.  
Refer to terms and conditions in the FUSO warranty booklet for full details.

## KERB WEIGHTS AND MAX AXLE LOADS (kg)

Model		Vehicle Ratings**		Max Axle Loadings**		Kerb Weights*		
		GVM	GCM	Front	Rear	Front	Rear	Total
4x2 FK1225H 6 Sp. Man Steel Susp.	FK62FHZ5RFAC(D)	12,000	N/A	5,000	9,200	2,380	1,610	3,990
4x2 FK1225L 6 Sp. Man Steel Susp.	FK62FLZ5RFAC(D)	12,000	N/A	5,000	9,200	2,500	1,605	4,105
4x2 FK1225L 5 Sp. Auto Steel Susp.	FK62FLZ5RFAD(D)	12,000	N/A	5,000	9,200	2,525	1,595	4,120
4x2 FK1225L 5 Sp. Auto Air Susp.	FK65FLZ5RFAD(D)	12,000	N/A	5,000	9,200	2,520	1,650	4,170

\* Weights (est.) includes 10L fuel and spare wheel and are subject to 2.5% variation (+/-) \*\* Vehicle ratings and max axle loadings may be limited by local regulations.

# SPECIFICATIONS - FIGHTER FK1225 **EURO 6**

## DIMENSIONS (mm)

	H Wheelbase	L Wheelbase
Wheelbase	4,270	5,210
Length Overall	7,220	8,645
Height Overall	2,530	2,530
Width Overall	2,270	2,270
Width Rear Axle	2,270	2,270
Width Front Track	1,780	1,780
Width Rear Track	1,710	1,710
Width Frame	844	844
Height Frame at Rear Axle	932	931 (Air Sus = 858 inflated)

## PERFORMANCE

	Manual	Auto
Turning Circle (kerb to kerb - metres)	H = 15.2 L = 18.2	18.2
Electronically Speed Limited to (km/h):	100	100
Engine Speed (rpm) at 90km/hr (top gear)	2130	2260
Gradeability at Rated GVM (theoretical)*	45%	37%

\*Theoretical performance only. Actual performance may vary under different conditions

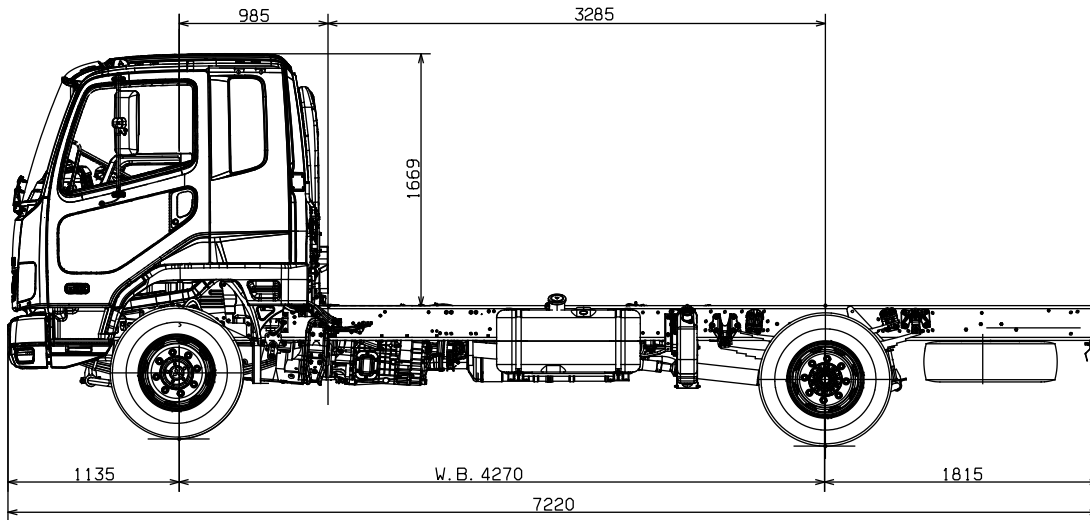

**FIGHTER FK1225 – 'H' WHEELBASE**

1000  
UNIT: mm 20mm=1m

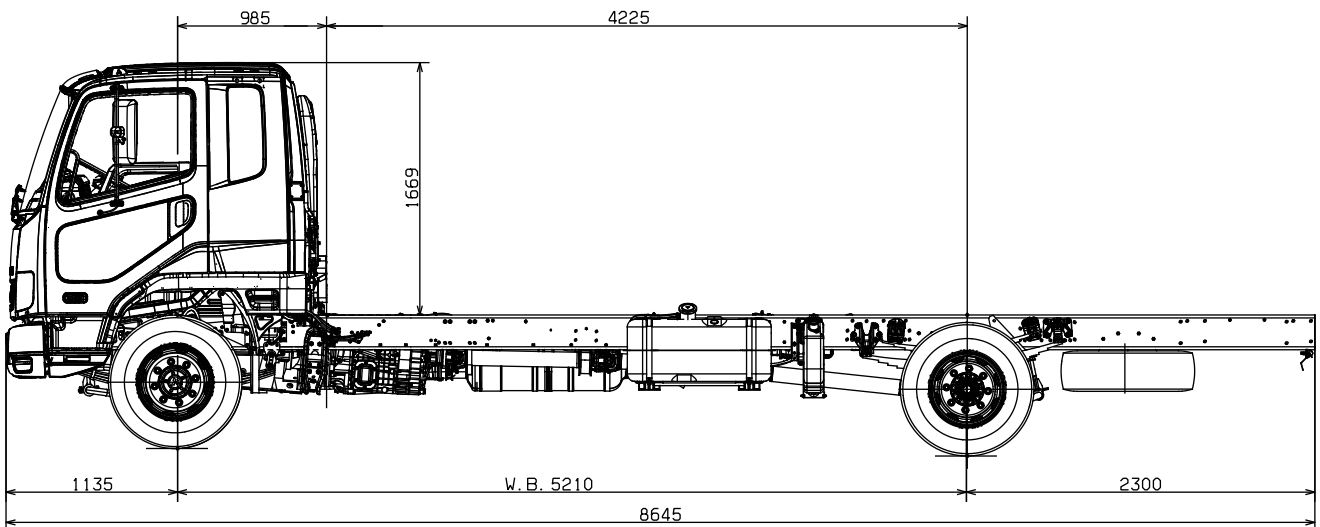

**FIGHTER FK1225 – 'L' WHEELBASE**

1000  
UNIT: mm 20mm=1m

Scale = 1:50 (20mm = 1 metre). This scale is accurate when used on the original spec sheet, be aware that enlarging these illustrations can alter the scale and cause incorrect measurements. Fuso New Zealand and its authorised dealers always recommend customers seek professional advice from independent sources before commencing any engineering activities.

A policy of continual improvement means that specifications detailed in this brochure are subject to change without notice. Contact your authorised Fuso dealer to confirm current specifications. Fuso is a registered trademark of Mitsubishi Fuso Truck & Bus Corporation. Copyright © Fuso NZ (2021)