

FIGHTER FK1428

EURO 6 • 4x2 • MANUAL



GVM:
14,000kg



Power / Torque:
207kW / 802Nm



Wheelbase:
5,210mm (L) / 5,540mm (M)

- **NEW** Euro 6 drivetrain
- **NEW** Advanced safety features
- **5yr / 300,000km Warranty** (T&Cs inside)
- High-torque engine
- Low-height chassis

SPECIFICATIONS - FIGHTER FK1428 EURO 6

MODEL

4x2 FK1428L	6 SP.	MAN	AIR SUSP.	FK65FLZ6RFAC
4x2 FK1428M	6 SP.	MAN	AIR SUSP.	FK65FMZ6RFAC

WHEELBASE (mm)

5,210 (L)
5,540 (M)

GVM (kg)

14,000
14,000

GCM (kg)

N/A
N/A

ENGINE

Engine Version	FUSO 6M60-CAT6 Diesel
Configuration	6 Cyl. In-line OHC, 4-Valve
Type	Variable Geometry Turbo Charged Air to Air Intercooler
Displacement	7.5 litre (7545cc)
Power ECE Nett	199kW @ 2500rpm
Torque ECE Nett	785Nm @ 1100-2400rpm
Power (JIS Gross)*	207kW (281ps) @ 2500rpm
Torque (JIS Gross)*	802Nm(592lbft) @ 1100-2400rpm
Maximum Engine Speed (rpm)	2900
Compression Ratio	16.0:1
Cooling System/Oil Cooler	Watercooled with Electronically Controlled Viscous Fan, 23L capacity. Engine oil cooler
Air Cleaner	Paper Element Type with Restrictor Indicator. Vertical Intake Mounted on Clean Air Side (RH)
Cold Start Preheat	Standard
Emission Control	Selective Catalytic Reduction (SCR + DPF)
Emission Level	Euro 6

*Calculated

6M60-CAT6

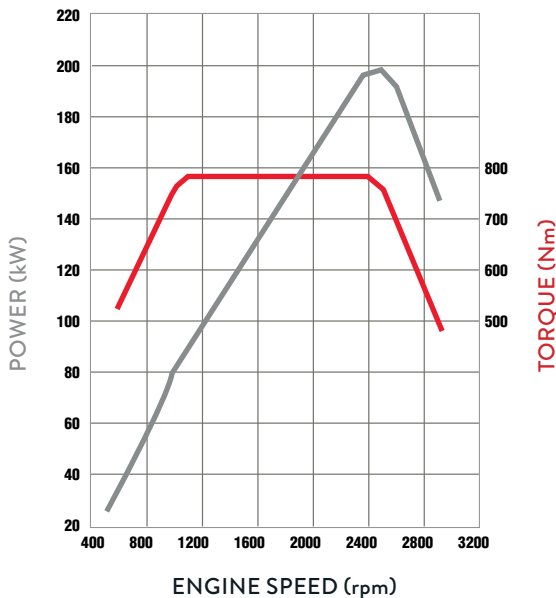

FUEL

Injection System	DENSO Common Rail System Electronically Controlled Direct Injection
Tank Type	Rectangular Steel Tank with Locking Cap
Fuel Capacity (L)	200
AdBlue Exhaust Fluid Capacity (L)	23

ELECTRICAL

Voltage	24V Negative Earth
Alternator Capacity	24V-80 amp
Battery Specification	Heavy Duty 2 x 12V, 100Ah/20hr

CLUTCH

Clutch Model	FUSO C7M38
Type	Single Plate Cerametallic 380mm
Operation/Specification	Air Assisted Hydraulic

TRANSMISSION

Version	FUSO Manual M070S6-OD
Type/Speeds	6 with Air Assisted Gearshift
Features	Synchromesh 2nd-6th
Ratios	1st: 6.807 2nd: 4.172 3rd: 2.396 4th: 1.504 5th: 1.000 6th: 0.774 Rev. 6.807
PTO Opening	LH Side

PROPELLER SHAFT

Type	P10
Universal Joint	Needle Roller

FRONT AXLE

Axle	FUSO F500T "I" Beam
Design Capacity (kg)	5,000
Max Operating Capacity (kg)	5,000

FRONT SUSPENSION

Type	Taper Leaf spring and Double Acting Shock Absorbers
Size (mm)	1,300 x 70

REAR AXLE

Axle	FUSO D052 Full Floating Hypoid
Design Capacity (kg)	9,500
Max Operating Capacity (kg)	9,200
Ratio	L wheelbase 4.875:1 M wheelbase 4.625:1

REAR SUSPENSION

Type	Trailing Arm + Air Dump Control, Double Acting Shock Absorbers & CLCS
Details	Air Spring (2 x 270 dia. per axle)
Air Spring	Chassis Level Control System, Electronic Height Control via steering wheel, 2 memory positions

NEW

STEERING

Power Assisted	Tilt/Telescopic Adjustable Steering Wheel
----------------	---

SPECIFICATIONS - FIGHTER FK1428 EURO 6



BRAKES

Type	Full Air, Dual Circuit, FUSO Taper Roller, Automatic Brake Adjustment, ABS
ASR (Traction Control)	Yes
Size Front/Rear (mm)	370 x 150
Park Brake	Rear Wheel Spring Actuated
Auxiliary	Exhaust Brake
Compressor	Water Cooled, 340cc Single Cyl. with Air Dryer

WHEELS AND TYRES

Wheel Type	7, Steel 19.5 x 6.75" ISO 8 Stud
Tyre Size (all)	265/70R19.5
Spare Tyre Carrier	Provided

CHASSIS

Type	Parallel Channel with Reinforcement
Size (mm)	230 x 80 x 8.0
Width (mm)	844

Refer to the bodybuilders guidelines on the Fuso website (www.fuso.co.nz) before mounting a body or modifying the chassis

INSTRUMENTS

Gauges	Speedo, Tacho, Air Pressure, Fuel, Ad Blue
Multi-Information Display (accessed from steering wheel buttons)	Hour Meter, Tripmeter, Outside Temp, Digital Speedo, Advanced Safety Systems control/warning, Water Temp, Fuel Consumption/Range, Cruise Control, DPF Information, Warning Lamps, Service Indicators, Oil Level, Alarm clock
Steering wheel controls	Audio / Phone/ Cruise control/ Multi-Information Display menu, Air suspension height, Idling speed adjustment

STANDARD FEATURES

Driving	Electric Windows, Keyless Central Locking, Fluorescent Cabin Lamp, Interior Reading Lamps, Engine Idle Speed Control
Storage	Centre Storage Console, Rear Bunk Storage Pocket, Dash Storage Tray 2 DIN Glove Compartment, 1 Single & 1 Double DIN Slot for Accessories, Overhead Storage Pocket with Lid, RH Door Storage Pocket, Cup Holders (4)
Cab Cooling/Heating	Air Conditioner / Heater / Demister
Accessory Power	24V Accessory Power Outlet

CAB FEATURES

Type	All Steel Forward Control, Manual Tilt 44 deg.
Mounting	Hydroelastic Susp. 4 Point
Colour	Natural White (W31)
Interior	Fully Trimmed + Heavy Duty Vinyl on floor
Door	90 degree Opening Angle
Seat (driver)	ISRI Air Susp. + Auto Levelling, Height, Tilt, Lumbar, Bolster + Dampening Adjust, Integral Headrest and Fabric Trim
Seats (passenger)	Centre: Low Back with Fabric Trim and Forward Folding. Far Passenger: Fixed Base with Reclining Seat Back, Integral Headrest and Fabric Trim
Seating Capacity	3
Cab: External	Roof Mounting Points (max. static load 50kg), Front End-Outline Marker Lamps

KERB WEIGHTS AND MAX AXLE LOADS (kg)

Model		Vehicle Ratings**		Max Axle Loadings**		Kerb Weights*		
		GVM	GCM	Front	Rear	Front	Rear	Total
4x2 FK1428L 6 Sp. Man Air Susp.	FK65FLZ6RFAC	14,000	N/A	5,000	9,200	2,545	1,620	4,165
4x2 FK1428M 6 Sp. Man Air Susp.	FK65FMZ6RFAC	14,000	N/A	5,000	9,200	2,555	1,630	4,185

* Weights (est.) includes 10L fuel and spare wheel and are subject to 2.5% variation (+/-) ** Vehicle ratings and max axle loadings may be limited by local regulations.

SAFETY FEATURES

ACTIVE SAFETY FEATURES

Electronic Stability Control	Yes	NEW
Active Emergency Braking System	Yes	NEW
Lane Departure Warning System	Yes	NEW
Active Attention Assist	Yes	NEW
Active Side Guard Assist	Yes	NEW

CAB

Structure	Reinforced, Side Door Intrusion Beams, Transom Window and Rear Quarter Glass, Front Underrun Protector Beam	NEW
Airbags	Driver Air Bag and Seat Belt Pre-tensioner	
Seatbelts	2 ELR Lap Sash, 1 Lap in centre seat	
Steering Wheel	Energy Absorbing, Tilt / Telescopic Adjustable	
Headlamp Auto Sensing	Halogen 2 x 70W / 75W	NEW
Day Time Running Lights	Yes	NEW
Fog Lamps	Yes	NEW
Rearview Mirrors	Remote Control / Heated with separate convex Spotter (Both Sides)	
Wipers	Auto Sensing	NEW
Keyless Central Locking + Immobiliser	Yes	NEW
6.2" Touchscreen Media Unit	AM/FM/DAB + USB + AUX, Apple Carplay / Android Auto, Wi-Fi enabled, Bluetooth, 32GB storage, HD Infrared Reverse Camera	
Connectivity	FMS CANBus Connector, ASAM Sensor Actuator Module	NEW

CHASSIS

Speed Limiter (100km/hr factory Set)	Yes (adjustable by FUSO dealer)
Cruise Control	Yes
Exhaust Brake	Yes
Anti-Lock Brakes (ABS)	Yes
Hill Start System	Yes
Traction Control (ASR)	Yes
Reverse Warning Buzzer	Yes

OPTIONS

Additional Cameras for Media Unit (up to 4), Truck Specific GPS Navigation, Reverse Sensors, Tyre Pressure Monitoring System (up to 36 tyres)

SERVICE INTERVALS

20,000km or 12 month full service intervals, depending on application/use.

WARRANTY

5 years / 300,000km cover

Simply have your vehicle serviced at an authorised FUSO Service Centre, at the recommended servicing intervals, and you are covered by an additional 2 year / 150,000km FUSO warranty on top of the first 3 years / 150,000km. That's a total of 5 years / 300,000km cover.

Refer to terms and conditions in the FUSO warranty booklet for full details.

SPECIFICATIONS - FIGHTER FK1428 **EURO 6**

DIMENSIONS (mm)

	L Wheelbase	M Wheelbase
Wheelbase	5,210	5,540
Length Overall	8,645	9,075
Height Overall	2,530	2,530
Width Overall	2,270	2,270
Width Rear Axle	1,710	1,710
Width Front Track	1,780	1,780
Width Rear Track	1,710	1,710
Width Frame	844	844
Height Frame at Rear Axle	858 Inflated	858 Inflated

PERFORMANCE

	L Wheelbase	M Wheelbase
Turning Circle (kerb to kerb - metres)	18.2	19.4
Electronically Speed Limited to(km/hr):	100	100
Engine Speed (rpm) at 90km/hr (top gear)	2130	2030
Gradeability at Rated GVM (theoretical)*	41%	38%

*Theoretical performance only. Actual performance may vary under different conditions

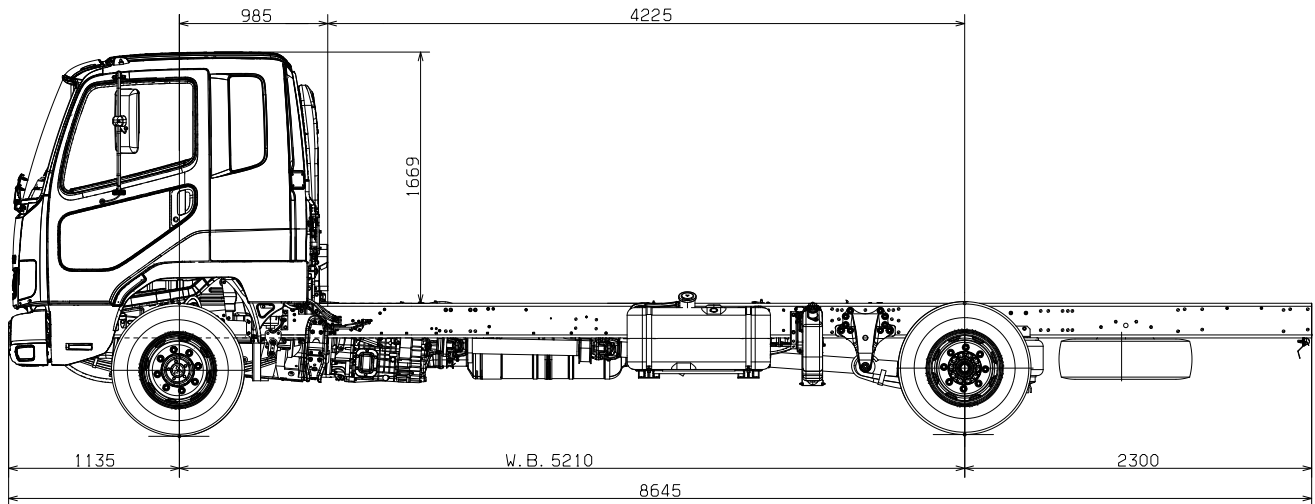

FIGHTER FK1428 – 'L' WHEELBASE

1000
UNIT: mm 20mm=1m

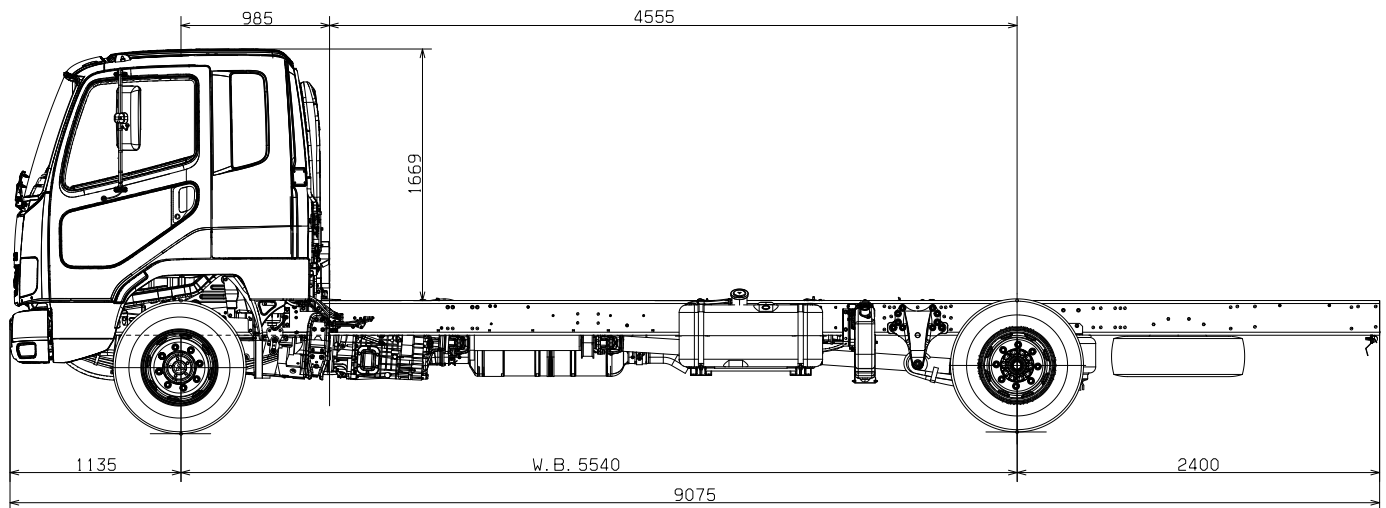

FIGHTER FK1428 – 'M' WHEELBASE

1000
UNIT: mm 20mm=1m

Scale = 1:50 (20mm = 1 metre). This scale is accurate when used on the original spec sheet, be aware that enlarging these illustrations can alter the scale and cause incorrect measurements. Fuso New Zealand and its authorised dealers always recommend customers seek professional advice from independent sources before commencing any engineering activities.

A policy of continual improvement means that specifications detailed in this brochure are subject to change without notice. Contact your authorised Fuso dealer to confirm current specifications. Fuso is a registered trademark of Mitsubishi Fuso Truck & Bus Corporation. Copyright © Fuso NZ (2021)