

FIGHTER FM1628

EURO 6 • 4x2 • **MANUAL** OR **ALLISON AUTO**



GVM:
16,000kg



Power / Torque:
207kW / 802Nm



Wheelbase:
4,280mm (H) / 5,550mm (M)

- **NEW** Euro 6 drivetrain
- **NEW** Advanced safety features
- **5yr / 300,000km Warranty** (T&Cs inside)
- 6spd or 9spd transmission
- 6.5T front axle

SPECIFICATIONS - FIGHTER FM1628 EURO 6

MODEL

4x2 FM1628H	9 SP.	MAN	STEEL SUSP.	FM65FH6RFAK
4x2 FM1628M	9 SP.	MAN	AIR SUSP.	FM67FM6RFAK
4x2 FM1628M	6 SP.	AUTO	AIR SUSP.	FM67FM6RFAJ

WHEELBASE (mm)

4,280 (H)
5,550 (M)
5,550 (M)

GVM (kg) (optional)

16,000 (12,000)
16,000 (12,000)
16,000 (12,000)

GCM (kg)

N/A
N/A
N/A

ENGINE

Engine Version	FUSO 6M60-CAT6 Diesel
Configuration	6 Cyl. In-line OHC, 4-Valve
Type	Variable Geometry Turbo Charged Air to Air Intercooler
Displacement	7.5 litre (7545cc)
Power ECE Nett	199kW @ 2500rpm
Torque ECE Nett	785Nm @ 1100-2400rpm
Power (JIS Gross)*	207kW (281ps) @ 2500rpm
Torque (JIS Gross)*	802Nm (592lbft) @ 1100-2400rpm
Maximum Engine Speed (rpm)	2900
Compression Ratio	16.0:1
Cooling System/Oil Cooler	Watercooled with Electronically Controlled Viscous Fan, 23L capacity. Engine oil cooler
Air Cleaner	Paper Element Type with Restrictor Indicator. Vertical Intake Mounted on Clean Air Side (RH)
Cold Start Preheat	Standard
Emission Control	Selective Catalytic Reduction (SCR + DPF)
Emission Level	EURO 6

*Calculated

6M60-CAT6

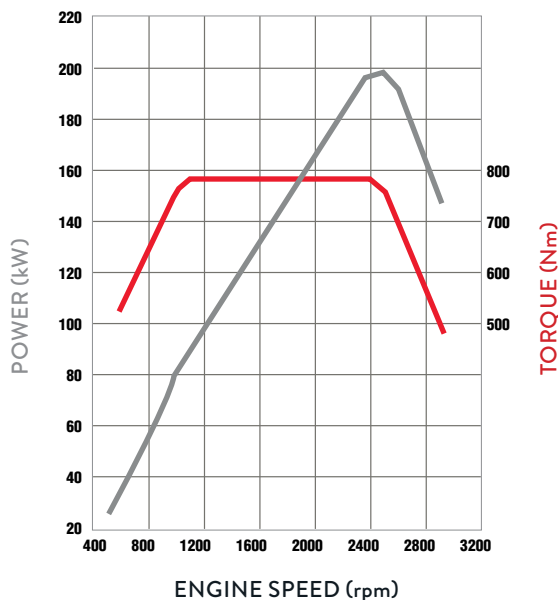

FUEL

Injection System	DENSO Common Rail System Electronically Controlled Direct Injection
Tank Type	Rectangular Steel Tank with Locking Cap
Fuel Capacity (L)	H wheelbase: 200 M wheelbase: 300
AdBlue Exhaust Fluid Capacity (L)	49

ELECTRICAL

Voltage	24V Negative Earth
Alternator Capacity	24V-80 amp
Battery Specification	Heavy Duty 2 x 12V, 100Ah/20hr

CLUTCH (manual)

Clutch Model	FUSO C7M38
Type	Single Plate Cerametallic 380mm
Operation/Specification	Air Assisted Hydraulic

TRANSMISSION

	Manual	Auto
Version	Eaton Manual ES-11109 (Fuso Code M060S9)	Allison Automatic MD3500 (M100A6)
Type/Speeds	9 Speed	6 Speed
Features	Synchromesh 1L-4H	Generation 5 Control Systems
Ratios	Low Range Low: 12.64 1st: 8.81 2nd: 6.55 3rd: 4.77 4th: 3.55 High Range 1st: 2.48 2nd: 1.85 3rd: 1.34 4th: 1.00 Rev: 13.21	1st: 4.593 2nd: 2.257 3rd: 1.535 4th: 1.000 5th 0.749 6th 0.651 Rev. 4.999
PTO Opening	LH Side / Rear	4 o'clock / 8 o'clock
Torque Converter/Stall Torque Ratio (Auto model)		TC415/2.35
Automatic Transmission Fluid Cooling (Auto model)		2 Chassis Mounted Coolers (LH & RH Side)

PROPELLER SHAFT

	Auto	9 Speed
Type	P10	P12
Universal Joint	Needle Roller	

FRONT AXLE

Axle	FUSO F650T "I" Beam
Design Capacity (kg)	6,500
Max Operating Capacity (kg)	6,500

FRONT SUSPENSION

Type	Taper Leaf spring with Double Acting Shock Absorbers
Size (mm)	1,400 x 80

REAR AXLE

	Manual	Auto
Axle	FUSO D10H Full Floating Hypoid	
Design Capacity (kg)	10,800	
Max Operating Capacity (kg)	10,000	
Ratio	H wheelbase M wheelbase	4.625 4.222:1
		6.166:1 (11R option 6.666)

REAR SUSPENSION

Type	Steel Suspension	Air Suspension
Details	Multi Leaf spring	Trailing Arm + Air Dump Control, Double Acting Shock Absorbers
Size Main Leaves (mm)	1,400 x 80	Air Spring (2 x 270 dia. per axle)
Size Helper Leaves (mm)	960 x 80	Trailing Arm - 2 leaf

SPECIFICATIONS - FIGHTER FM1628 EURO 6



STEERING

Power Assisted	Tilt/Telescopic Adjustable Steering Wheel
----------------	---

BRAKES

Type	Full Air, Dual Circuit, FUSO Taper Roller, Automatic Brake adjustment, ABS
ASR (Traction Control)	Yes
Size Front / Rear (mm)	410 x 150 / 410 x 200
Park Brake	Rear Wheel Spring Actuated
Auxiliary	Exhaust Brake
Compressor	Water Cooled, 340cc Single Cylinder with air dryer

WHEELS AND TYRES

	Manual	Auto
Wheel Type	7, Steel 22.5x8.25" ISO 10 Stud	
Tyre Size (all)	H wheelbase 11R22.5 M wheelbase 275/70R22.5	275/70R22.5 (Optional 11R22.5)
Spare Tyre Carrier	Provided	

CHASSIS

Type	Reinforced Parallel Channel
Size (mm)	280 x 90 x 8.0
Width (mm)	841

Refer to the bodybuilders guidelines on the Fuso website (www.fuso.co.nz) before mounting a body or modifying the chassis

INSTRUMENTS

Gauges	Speedo, Tacho, Air Pressure, Fuel, Ad Blue
Multi-Information Display (accessed from steering wheel buttons)	Hour Meter, Tripmeter, Outside Temp, Digital Speedo, Advanced Safety Systems control/warning, Water Temp, Fuel Consumption/Range, Cruise Control, DPF Information, Warning Lamps, Service Indicators, Oil Level, Alarm clock
Steering wheel controls	Audio/Phone/Cruise control / Multi-Information Display menu, Air suspension height, Idling speed adjustment

STANDARD FEATURES

Driving	Electric Windows, Keyless Central Locking, Fluorescent Cabin Lamp, Interior Reading Lamps, Engine Idle Speed Control
Storage	Centre Storage Console, Rear Bunk Storage Pocket, Dash Storage Tray 2 DIN Glove Compartment, 1 Single & 1 Double DIN Slot for Accessories, Overhead Storage Pocket with Lid, RH Door Storage Pocket, Cup Holders (4)
Cab Cooling/Heating	Air Conditioner / Heater / Demister
Accessory Power	24V Accessory Power Outlet

CAB FEATURES

Type	All Steel Forward Control, Manual Tilt 44 deg.
Mounting	Hydroelastic Susp. 4 Point
Colour	Natural White (W31)

SAFETY FEATURES

ACTIVE SAFETY FEATURES

Electronic Stability Control	Yes	NEW
Active Emergency Braking System	Yes	NEW
Lane Departure Warning System	Yes	NEW
Active Attention Assist	Yes	NEW
Active Side Guard Assist	Yes	NEW

CAB

Structure	Reinforced, Side Door Intrusion Beams, Transom Window and Rear Quarter Glass, Front Underrun Protector	NEW
Airbags	Driver Air Bag and Seat Belt Pre-tensioner	
Seatbelts	2 ELR Lap Sash, 1 Lap in centre seat	
Steering Wheel	Energy Absorbing, Tilt / Telescopic Adjustable	
Headlamp Auto Sensing	Halogen 2 x 70W / 75W	NEW
Day Time Running Lights	Yes	NEW
Fog Lamps	Yes	NEW
Rearview Mirrors	Remote Control / Heated with separate convex Spotter (Both Sides)	
Wipers	Auto Sensing	NEW
Keyless Central Locking + Immobiliser	Yes	NEW
6.2" Touchscreen Media Unit	AM/FM/DAB + USB + AUX, Apple Carplay / Android Auto, Wi-Fi enabled, Bluetooth, 32GB storage, HD Infrared Reverse Camera	
Connectivity	FMS CANBus Connector, ASAM Sensor Actuator Module	NEW

CHASSIS

Speed Limiter (100km/hr factory set)	Yes (adjustable by FUSO dealer)
Cruise Control	Yes
Exhaust Brake	Yes
Anti-Lock Brakes (ABS)	Yes
Hill Start System	Yes (not available on auto model)
Traction Control (ASR)	Yes
Reverse Warning Buzzer	Yes

CAB FEATURES (continued)

Interior	Fully Trimmed + Heavy Duty Vinyl on floor
Door	90 degree Opening Angle
Seat (driver)	ISRI Air Susp. + Auto Levelling, Height, Tilt, Lumbar, Bolster + Dampening Adjust, Integral Headrest, Fabric Trim
Seats (passenger)	Centre: Low Back with Fabric Trim and Forward Folding Far Passenger: Fixed Base with Reclining Seat Back, Integral Headrest and Fabric Trim
Seating Capacity	3
Cab: External	Roof Mounting Points (max. static load 50kg), Front End-Outline Marker Lamps

KERB WEIGHTS AND MAX AXLE LOADS (kg)

Model		Vehicle Ratings**		Max Axle Loadings**		Kerb Weights*		
		GVM	GCM	Front	Rear	Front	Rear	Total
4x2 FM1628H 9 Sp. Man Steel Susp.	FM65FH6RFAK	16,000	N/A	6,500	10,000	2,985	1,985	4,970
4x2 FM1628M 9 Sp. Man Air Susp.	FM67FM6RFAK	16,000	N/A	6,500	10,000	3,045	2,000	5,045
4x2 FM1628M 6 Sp. Auto Air Susp.	FM67FM6RFAJ	16,000	N/A	6,500	10,000	3,090	2,060	5,150
4x2 FM1228H 9 Sp. Man Steel Susp.	FM65FH6RFAK(D)	12,000	N/A	6,500	10,000	2,985	1,985	4,970
4x2 FM1228M 9 Sp. Man Air Susp.	FM67FM6RFAK(D)	12,000	N/A	6,500	10,000	3,045	2,000	5,045
4x2 FM1228M 6 Sp. Auto Air Susp.	FM67FM6RFAJ(D)	12,000	N/A	6,500	10,000	3,090	2,060	5,150

* Weights (est.) includes 10L fuel and spare wheel and are subject to 2.5% variation (+/-)

** Vehicle ratings and max axle loadings may be limited by local regulations.

SPECIFICATIONS - FIGHTER FM1628 **EURO 6**

SERVICE INTERVALS

20,000km or 12 month full service intervals, depending on application/use.

DIMENSIONS (mm)

	H Wheelbase	M Wheelbase
Wheelbase	4,280	5,550
Length Overall	7,455	9,325
Height Overall	2,675	2,630 (manual) / 2,670 (auto)
Width Overall	2,470	2,470
Width Rear Axle	2,470	2,470
Width Front Track	1,925	1,925
Width Rear Track	1,850	1,850
Width Frame	841	841
Height Frame at Rear Axle	Spring Suspension 1,075	Air Suspension (inflated) With 275/70R22.5: 969 With 11R22.5: 1,012

OPTIONS

Additional Cameras for Media Unit (up to 4), Truck Specific GPS Navigation, Reverse Sensors, Tyre Pressure Monitoring System (up to 36 tyres)

WARRANTY

5 years / 300,000km cover. Simply have your vehicle serviced at an authorised FUSO Service Centre, at the recommended servicing intervals, and you are covered by an additional 2 year / 150,000km FUSO warranty on top of the first 3 years / 150,000km. That's a total of 5 years / 300,000km cover. Refer to terms and conditions in the FUSO warranty booklet for full details.

PERFORMANCE

	Manual	Auto
Turning Circle (kerb to kerb - metres)	H wheelbase 14.6 M wheelbase 18.4	18.4
Electronically Speed Limited to (km/hr):	100	100
Engine Speed (rpm) at 90km/hr (top gear)	2,185	2,050
Gradeability at Rated GVM (theoretical)*	54%	69%

*Theoretical performance only. Actual performance may vary under different conditions

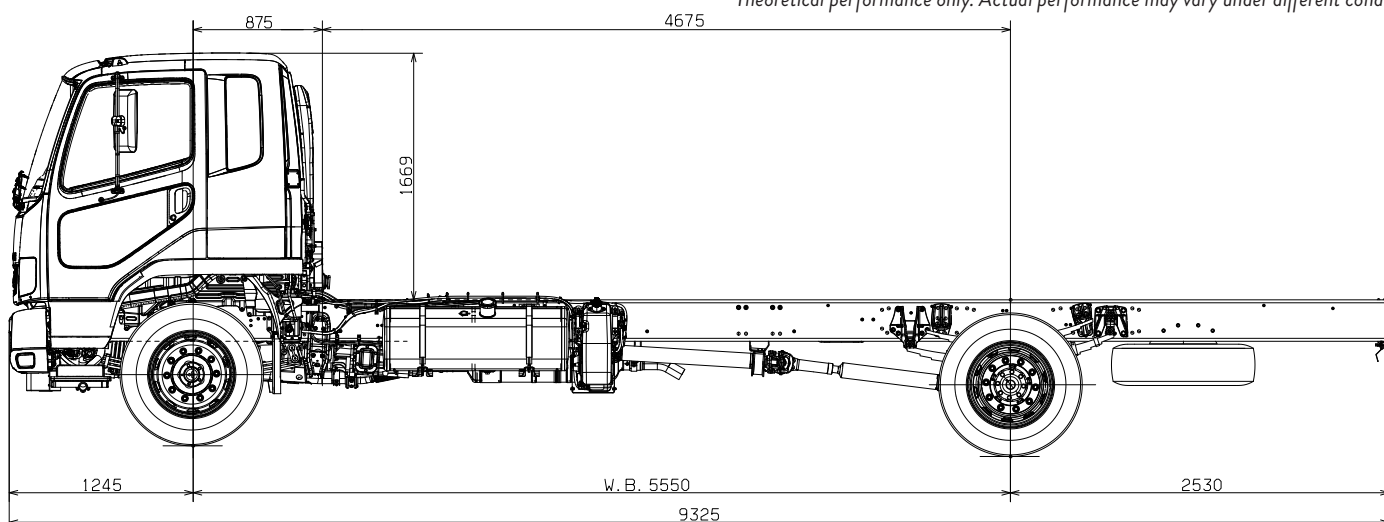

FIGHTER FM1628 – 'M' WHEELBASE

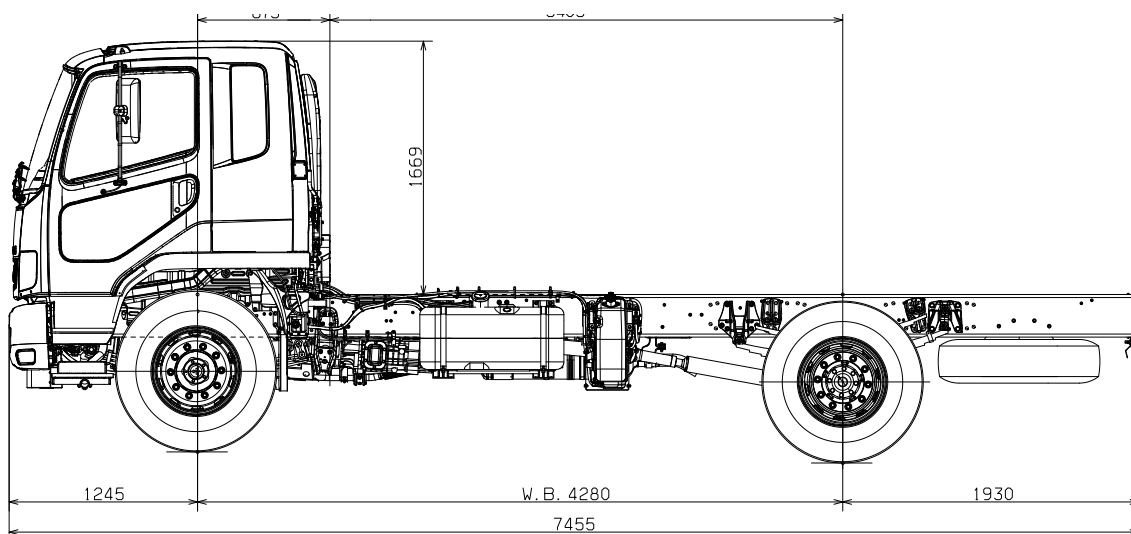

FIGHTER FM1628 – 'H' WHEELBASE

Scale = 1:50 (20mm = 1 metre). This scale is accurate when used on the original spec sheet, be aware that enlarging these illustrations can alter the scale and cause incorrect measurements. Fuso New Zealand and its authorised dealers always recommend customers seek professional advice from independent sources before commencing any engineering activities.

A policy of continual improvement means that specifications detailed in this brochure are subject to change without notice. Contact your authorised Fuso dealer to confirm current specifications. Fuso is a registered trademark of Mitsubishi Fuso Truck & Bus Corporation. Copyright © Fuso NZ (2021)