

# CANTER 516

## DUONIC AMT

ADVANCED  
SAFETY  
SYSTEMS



**GVM:**  
4,983kg



**Power/Torque:**  
110kW/370Nm



**Wheelbase:**  
2,800mm (C)

- Electronic Brake System **NEW**
- Electronic Stability Control **NEW**
- Active Emergency Braking System **NEW**
- Lane Departure Warning System **NEW**
- 5yr/200,000km warranty **NEW**
- 30,000km service intervals

# SPECIFICATIONS - CANTER 516

## MODEL

4x2 516 WIDE CAB 6 SP. AMT FEB21CR3SFBC

## WHEELBASE (mm)

2,800 (C)

## GVM (kg)

4,983

## GCM (kg)

8,483

## ENGINE

Engine Version	FUSO 4P10-T4 Euro 5 Diesel
Configuration	4 Cyl. In-line DOHC, 4-Valve
Type	Variable Geometry Turbo Charged Air to Air Intercooled
Displacement	3 litre (2998cc)
Power (DIN)	110kW @ 2840~3500rpm
Torque (DIN)	370Nm @ 1350~2840rpm
Maximum Engine Speed	4100rpm
Compression Ratio	17.5:1
Cooling System / Oil Cooler	Water cooled with Viscous fan, 13.7L capacity. Engine oil cooler
Air Cleaner	Paper Element Type with Restrictor Indicator. Vertical Intake Mounted on Clean Air Side (RH)
Cold Start Preheat	Standard
Emission Control	Diesel Particulate Filter (DPF) Exhaust Dash Display DPF Status 0~9 (Empty~Full) Parked Regeneration possible from 7~9
Emission Level	EURO 5 (ADR 80/03) and EEV rated (Enhanced Environmentally-Friendly Vehicle)

## 4P10-T4

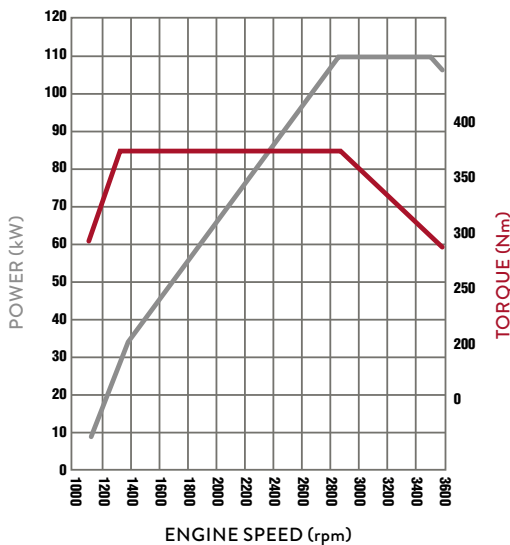

## FUEL

Injection System	Bosch Common Rail Direct Injection Bosch Piezo Technology Injectors
Tank Type	Rectangular Steel Tank with Locking Cap
Fuel Capacity (L)	100
Filtration	Filter with Water Separator and Indicator Sensor

## ELECTRICAL

Voltage	12V Negative Earth
Alternator Capacity	12V-110 amp
Battery Specification	Heavy Duty 115D31L x 2
Headlamp Type	Halogen 2 x 55W/60W
Fog lamp in bumper	Standard

## CLUTCH

Clutch Model	Duonic Automated Manual (no clutch pedal)
Type	Dual Clutch (Wet Multi-plate)

## TRANSMISSION

Version	FUSO Duonic M038S6
Type/Speeds	6 Speed Automated Manual with Auto and Manual Modes
Features	Virtually Instant Gear Changes; In-Dash Gear Lever with Park Brake Position; ECO Mode to Minimise Fuel Usage
Ratios	1st: 5.397 2nd: 3.788 3rd: 2.310 4th: 1.474 5th: 1.000 6th: 0.701 Rev. 5.397
PTO Opening	LH Side.

## FRONT AXLE

Axle	FUSO F200T Independent Front Suspension Type
Design Capacity (kg)	2,300
Max Operating Capacity (kg)	2,180

## FRONT SUSPENSION

Type	Double Wishbone Independent Front Suspension with Coil Springs and Shock Absorbers
------	--

## REAR AXLE

Axle	FUSO D03 Full Floating Banjo Type
Ratio	4.444:1
Design Capacity (kg)	3,800
Max Operating Capacity (kg)	3,800

## REAR SUSPENSION

Type	Steel Suspension
Details	Taper Leaf Spring with Stabiliser Bar and Double Acting Shock Absorbers
Size Main Leaves (mm)	1,100 x 70

## STEERING

Power Assisted	Tilt/Telescopic Adjustable Steering Wheel
----------------	---

## BRAKES

Type	Hydraulic Dual Circuit with Front and Rear Single Caliper Discs
Size Front / Rear (mm)	276 x 28
Features	ABS + EBD + EBS Exhaust Brake Brake Priority System
Park Brake	Transmission Mounted

# SPECIFICATIONS - CANTER 516

ADVANCED  
SAFETY  
SYSTEMS

## WHEELS AND TYRES

Wheel Size	16.0 x 5.5K-115
Tyre Size All	185 / 85R16
Spare Tyre Carrier	Yes

## CHASSIS

Size (mm)	188 x 60 x 4
-----------	--------------

Refer to the bodybuilders guidelines on the Fuso website ([www.fuso.co.nz](http://www.fuso.co.nz)) before mounting a body or modifying the chassis

## INSTRUMENTS

Gauges	Speedometer with Odometer; Tachometer; Fuel Level; Water Temperature
Colour Information Display	Fuel Consumption; DPF Bar Chart from 1~9 Water Temperature Maintenance Reminder System Tripmeters

## STANDARD FEATURES

Cab Cooling and Heating	Air Conditioner / Heater / Demister
Accessory Power	12V Accessory Power Outlet / Cigar Lighter
Driving	Keyless Central Locking Electric Windows
Storage	Dual Overhead Storage Pockets In-Dash Centre Document Storage Door Storage Pockets Lockable Glove Box

## CAB FEATURES

Type	All Steel Forward Control Manual Tilt
Mounting	Hydroelastic 4 Point
Interior	Fully Trimmed cab with vinyl floor covering
Seating Capacity	3
Seat (driver)	Heavy Duty Suspended with LH Arm Rest, Adjustable Lumbar Support and Weight Adjustment
Seats (passenger)	Flat Folding, 2 Passenger Bench

## SERVICE INTERVALS

**30,000km full service / 15,000km safety inspection**  
30,000km full service intervals, depending on application/use.  
15,000km safety inspection, with greasing, required to maintain warranty cover and ensure optimum performance.

## WARRANTY

**5 years / 200,000km**

Simply have your vehicle serviced at an authorised FUSO Service Centre, at the recommended servicing intervals, and you are covered by an additional 2 year / 100,000km FUSO warranty on top of the first 3 years / 100,000km. That's a total of 5 years / 200,000km cover. Refer to terms and conditions in the FUSO warranty booklet for full details.

**NEW**

## SAFETY FEATURES

### ACTIVE SAFETY FEATURES

Electronic Brake System (EBS)	Yes	<b>NEW</b>
Electronic Stability Control (ESC)	Yes	<b>NEW</b>
Active Emergency Braking System (AEBS)	Yes	<b>NEW</b>
Lane Departure Warning System (LDWS)	Yes	<b>NEW</b>

### CAB

Structure	ECE R-29 Reinforced Cab Side Intrusion Bar
Airbags	Driver's (steering wheel) Passenger's (dashboard) <b>NEW</b>
Seatbelts	ELR 3-Point (+ height-adjustable with pre tensioner for driver) Lap Belt (centre passenger)
Driver's Seat	Spring-suspended
Steering Wheel	Energy-absorbing Adjustable (height and reach)
Rearview Mirrors	Heated
Fog Lamps	Yes
Keyless Central Locking	Yes
7" Touchscreen Media Unit	AM/FM/DAB + USB + AUX <b>NEW</b> Apple CarPlay and Android Auto Wi-Fi enabled for Internet Radio Bluetooth 32GB capacity storage HD Reverse Camera included †

### CHASSIS

Speed Limiter	Yes (activated and adjustable by FUSO dealer)
Anti-Lock Braking System (ABS)	Yes
Anti-Slip Regulator (ASR)	Yes
Electronic Brake Force Distribution (EBD)	Yes
Disc Brakes	Auto-Adjusting, 4 Wheel Single Caliper
Brake Priority System	Yes
Exhaust Brake	Yes
Hill Start Assist	Yes
Reverse Warning Buzzer	Yes
Anti Roll Bar	Yes
Brake Wear Indicator	Yes

### OPTIONS

† Additional Multimedia Display Cameras (up to 4)
Truck Specific GPS Navigation
Reversing Sensors
Tyre Pressure Monitoring System
Wireless Phone Charge Pocket

## KERB WEIGHTS AND MAX AXLE LOADS (kg)

Model		Vehicle Ratings**		Max Axle Loadings**		Kerb Weights*		
		GVM	GCM	Front	Rear	Front	Rear	Total
4x2 516 Wide Cab 6 Sp. AMT	FEB21CR3SFBC	4,983	8,483	2,180	3,800	1,480	585	2,065

\* Weights (est.) includes 10L fuel and spare wheel and are subject to 2.5% variation (+/-)

\*\* Vehicle ratings and max axle loadings may be limited by local regulations.

# SPECIFICATIONS - CANTER 516

## PERFORMANCE

Turning Circle (kerb to kerb - metres)	9.6
Road Speed (km/h) at Max Engine Speed	136
Est Engine RPM at 90km/hr (top gear)	2110
Gradeability at Rated GVM (theoretical)*	40%

**Notes** \*This is theoretical performance only. Actual performance may vary under different conditions

## DIMENSIONS (mm)

Length Overall	5,135
Height Overall	2,165
Width Overall	1,955
Width Rear Axle	1,925
Width Front Track	1,655
Width Rear Track	1,495
Width Frame	750
Height Frame at Rear Axle	732

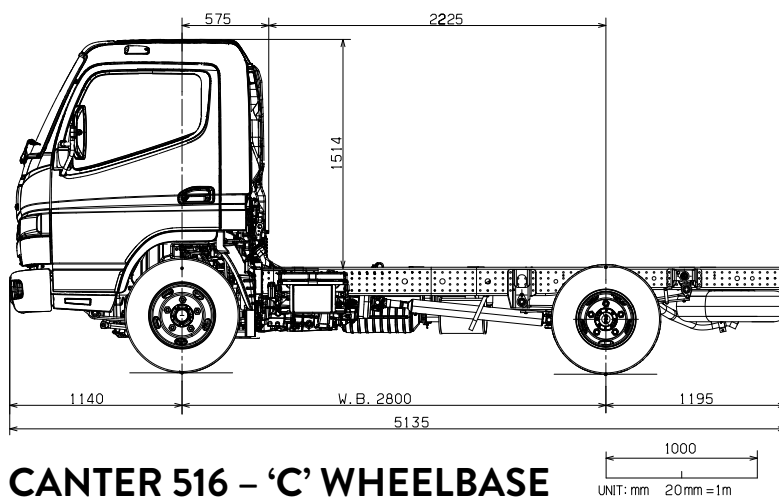

Scale = 1:50 (20mm = 1 metre). This scale is accurate when used on the original spec sheet, be aware that enlarging these illustrations can alter the scale and cause incorrect measurements. Fuso New Zealand and its authorised dealers always recommend customers seek professional advice from independent sources before commencing any engineering activities.

A policy of continual improvement means that specifications detailed in this brochure are subject to change without notice. Contact your authorised Fuso dealer to confirm current specifications. Fuso is a registered trademark of Mitsubishi Fuso Truck & Bus Corporation. Copyright © Fuso NZ (2021)